



Woodsmith **PLANS**

# PORTABLE DOVETAIL JIG WORKCENTER



# DOVETAIL JIG WORKCENTER

*Accuracy, convenience, and storage. You get it all with this simple workcenter for your dovetail jig.*



**T**he dovetail jig gets a lot of use in my shop. But there are a few things that can be an inconvenience when using it. My biggest complaint is that I have to stoop over to see what I'm doing as I work. Another problem is keeping the workpieces clamped square. And finally, when I'm done for the day, I have to find a place to store the jig and accessories.

The handy workcenter you see in the photo solves all these problems. For starters, it makes a great platform for any dovetail jig. By raising everything to a

comfortable height, it's easier to guide the router. Support bars help keep the workpieces square and position them properly for accurate results.

Plus, there are some other great features. There are "wings" that fold down. They make a handy landing spot to dock your router during use without damaging the bit or your benchtop. And there's plenty of storage in the large drawer down below.

Once you build this workcenter, you'll find that using your dovetail jig is a whole lot easier.

# Construction Details

Overall Dimensions:  
14" x 28" x 9" (stored size)

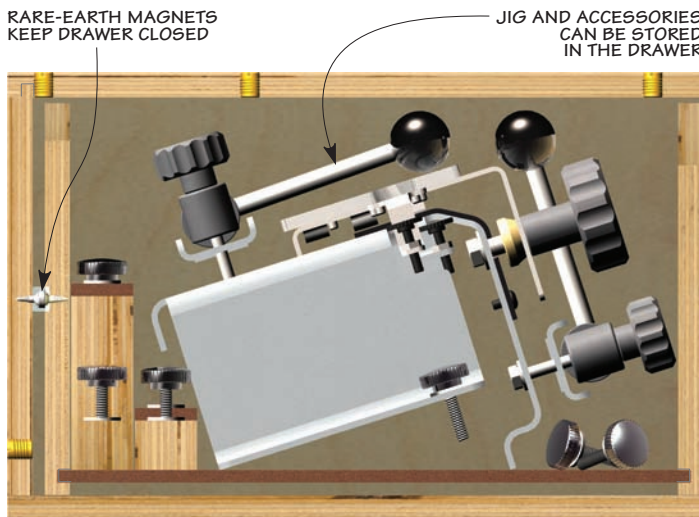
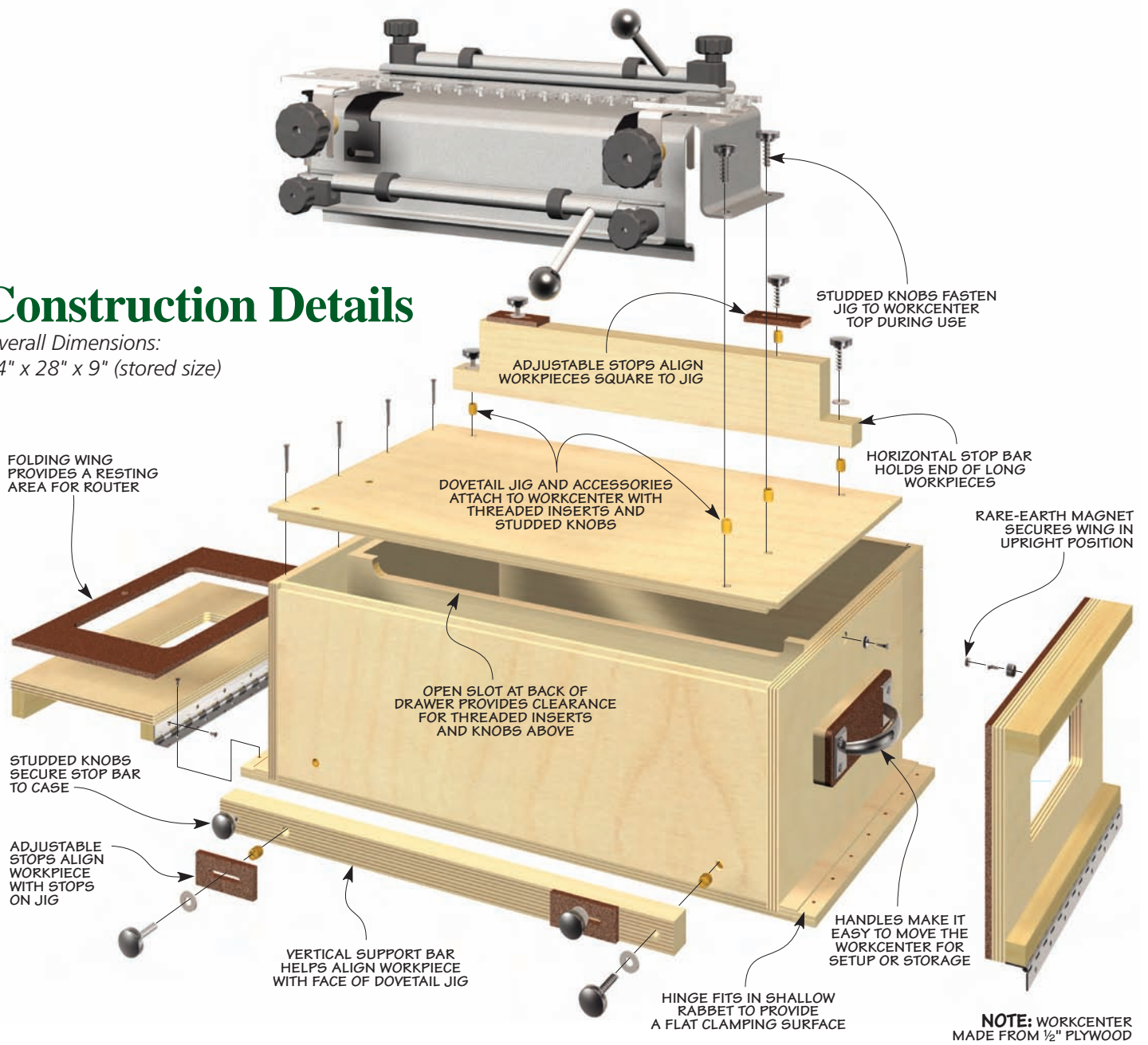

**SIDE SECTION VIEW**  
(DRAWER STORAGE DETAIL)



▲ **Tucked Away.** The large drawer is sized to hold the jig, templates, support bars, and knobs. And with the wings folded up, the workcenter stores neatly away.

## Strong & Sturdy Case

In the drawings below, you'll see that the workstation starts out as a simple box. As a matter of fact, it's a lot like a cabinet with a top, bottom, and two sides. But unlike a normal cabinet, the front is a solid panel. And the back is open for the large storage drawer.

For now, you'll concentrate on building the basic box, starting with the sides then adding the top and bottom pieces. Later you'll add the folding wings, a handle, and the storage drawer.

There's one thing you need to know before you get started. My workcenter was sized for the Porter-Cable 4212 dovetail jig. If you have a different jig, you may need to make some adjustments to the size of the case, the height of the support bars, and the drawer.

**SIDES.** I started on the case by cutting the sides to size. Then you just need to cut grooves for the front panel before moving on to the top and bottom pieces.

**TOP & BOTTOM.** If you take a close look at Figure 1a below, you can see how the sides of the case fit into dadoes on the bottom piece and rabbets on the top.



▲ **Compact.** With the wings folded up and the jig inside, you can store the workcenter away.



▲ **Home Base.** The folding wing makes a handy spot for you to set your router when using your jig.

It can be tricky to get these joints to line up so the case ends up square. To get around this problem, I cut the top and bottom pieces to the same size, then cut matching dadoes in both. The next step is to trim the waste off the ends of the top piece to form rabbets, as illustrated in Figure 1 below.

There are a couple of other things you need to do. First, the top needs a groove along the front edge to capture the front panel (Figure 1b). On the bottom, cut a shallow rabbet on each end for the hinges that will be attached later.

(Here it's a good idea to have the hinges in hand so you can make sure the hinge leaf sits flush.)

**FRONT.** All you need to do to make the front panel is cut it to size, then rabbet the top and sides to create a tongue. Aim for a snug fit of the tongues in the grooves. Finally, you can assemble the case with glue and screws.

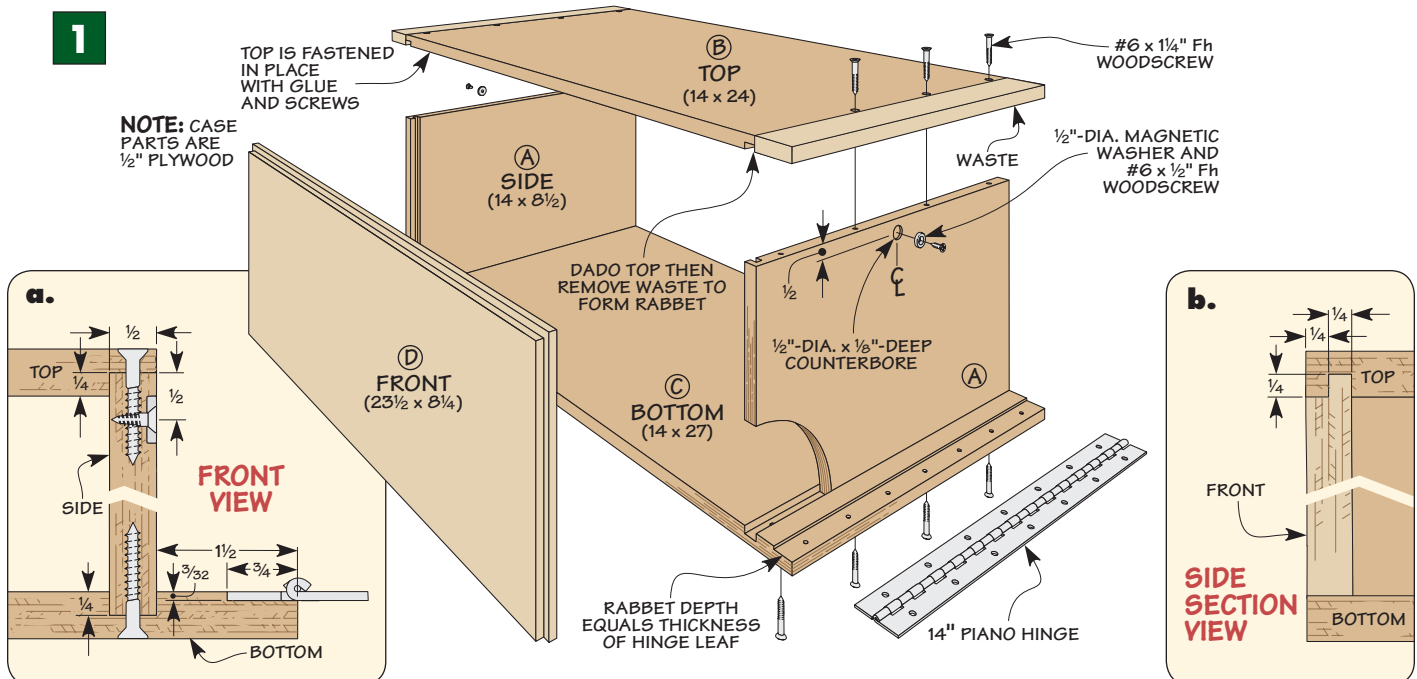

## FOLD-DOWN WINGS

With the shell of the case complete, you can start working on the hinged wings at each end.

If you take a look at Figure 2, you'll see that the wings have an opening in the center. These cutouts serve double duty. With the wings folded down, the cutouts make a convenient resting spot for your router. And when the wings are folded up, the cutout provides access to the carrying handle. You'll build the wings first, then fit the handles in the openings, as shown in Figures 2 and 3 at right.

**TRAY.** The trays for the wings start with a piece of plywood with a center cutout. On top of that is a piece of hardboard with a larger opening sized to fit the base of your router. I cut all the pieces to size first and then cut the openings.

**CUTOUTS.** To make the cutouts, first drill a hole at each corner. A jig saw makes quick work of "connecting the dots" to remove the waste. With these pieces done, you can glue the hardboard to the plywood and move on to the hinge block and the foot that supports the tray when it's folded down.

**HINGE BLOCK.** The hinge block is where you'll attach one leaf of the hinge. The goal is to have the tray flush with the top of the case when the wing is in the upright position. I found it easiest to attach the hinge to the case bottom and the hinge block first. Then you can glue the block to the tray.

**FOOT BLOCK.** The foot block is sized so that the tray sits parallel to the bench when it's in the open position. Just cut the foot block to fit and glue it to the tray.

**FINAL STEPS.** The last step to completing the wings is to install the rare-earth magnets and washers, as shown in Figure 2.

**HANDLES.** The handles fasten to a handle block and hardboard spacer (Figure 3). They fit inside the cutouts in the trays. I attached them while the wing was closed so I could position them properly. Finally, you can add the handle.

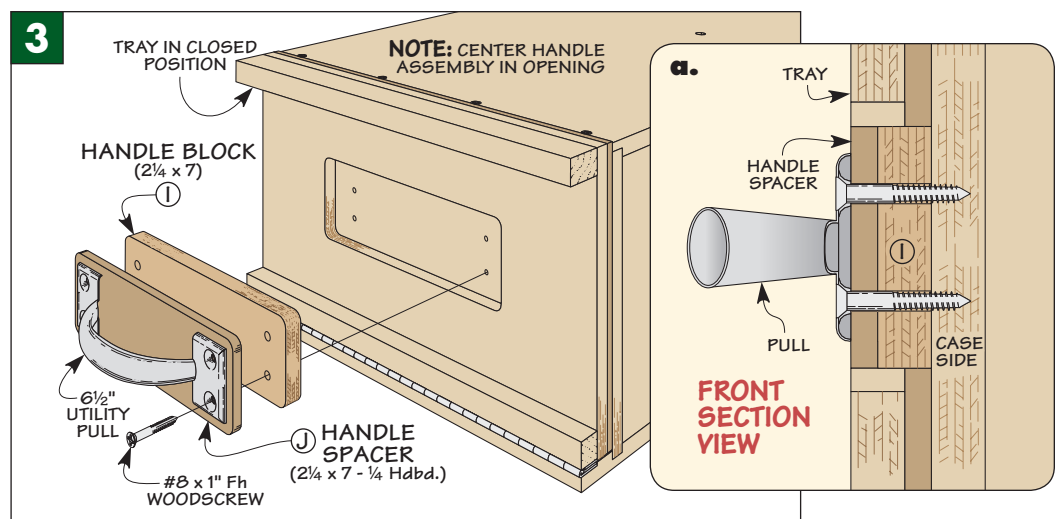
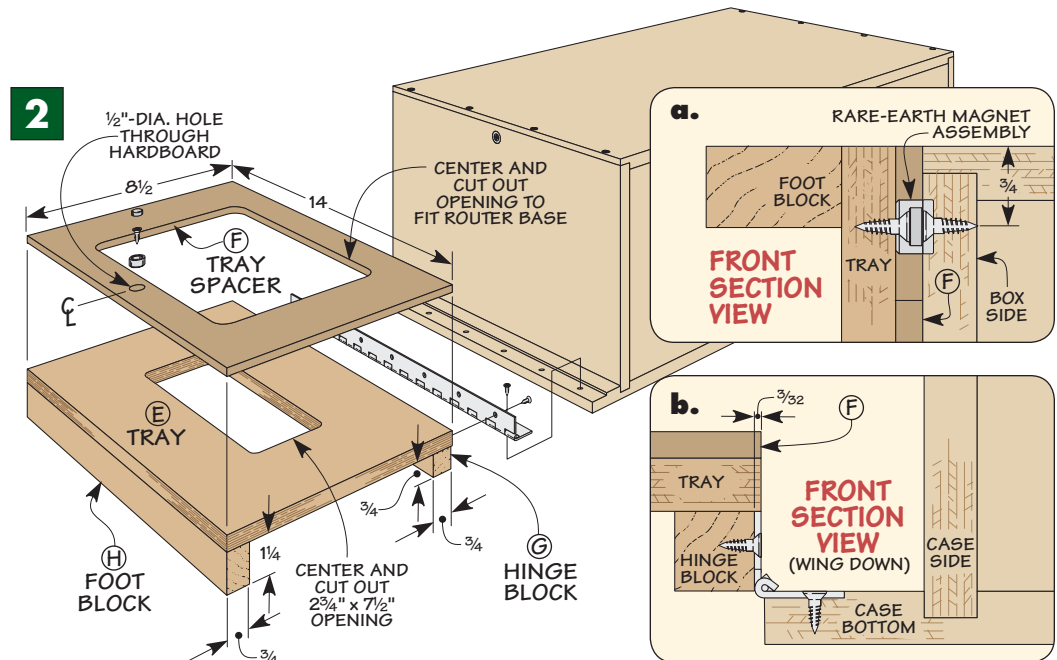

## MATERIALS & HARDWARE

<b>A</b> Sides (2)	14 x 8 <sup>1</sup> / <sub>2</sub> - 1 <sup>1</sup> / <sub>2</sub> Ply.	(2) 1 <sup>1</sup> / <sub>2</sub> "-dia. Rare-Earth Magnets w/Cups, Washers, and Screws
<b>B</b> Top (1)	14 x 24 - 1 <sup>1</sup> / <sub>2</sub> Ply.	(26) No. 6 x 1 <sup>1</sup> / <sub>4</sub> " Fh Woodscrews
<b>C</b> Bottom (1)	14 x 27 - 1 <sup>1</sup> / <sub>2</sub> Ply.	(8) No. 8 x 1" Fh woodscrews
<b>D</b> Front (1)	23 <sup>1</sup> / <sub>2</sub> x 8 <sup>1</sup> / <sub>4</sub> - 1 <sup>1</sup> / <sub>2</sub> Ply.	(12) 1 <sup>1</sup> / <sub>4</sub> " Washers
<b>E</b> Trays (2)	14 x 8 <sup>1</sup> / <sub>2</sub> - 1 <sup>1</sup> / <sub>2</sub> Ply.	(8) Round Knobs with 1 <sup>1</sup> / <sub>4</sub> " - 20 x 3 <sup>3</sup> / <sub>4</sub> " stud
<b>F</b> Tray Spacers (2)	14 x 8 <sup>1</sup> / <sub>2</sub> - 1 <sup>1</sup> / <sub>4</sub> Hdbd.	(4) Round Knobs with 1 <sup>1</sup> / <sub>4</sub> " - 20 x 1 <sup>1</sup> / <sub>2</sub> " stud
<b>G</b> Hinge Blocks (2)	3 <sup>3</sup> / <sub>4</sub> x 3 <sup>3</sup> / <sub>4</sub> - 14	
<b>H</b> Foot Blocks (2)	3 <sup>3</sup> / <sub>4</sub> x 1 <sup>1</sup> / <sub>4</sub> - 14	
<b>I</b> Handle Blocks (2)	7 x 2 <sup>1</sup> / <sub>4</sub> - 1 <sup>1</sup> / <sub>2</sub> Ply.	
<b>J</b> Handle Spacers (2)	7 x 2 <sup>1</sup> / <sub>4</sub> - 1 <sup>1</sup> / <sub>4</sub> Hdbd.	
<b>K</b> Front Stop Bars (1)	1 x 20 <sup>1</sup> / <sub>2</sub> - 1 <sup>1</sup> / <sub>2</sub> Ply.	
<b>L</b> Top Stop Bars (3)	3 <sup>1</sup> / <sub>2</sub> x 20 <sup>1</sup> / <sub>2</sub> - 1 <sup>1</sup> / <sub>2</sub> Ply.	
<b>M</b> Adjustable Stops (4)	1 <sup>1</sup> / <sub>2</sub> x 2 <sup>1</sup> / <sub>2</sub> - 1 <sup>1</sup> / <sub>4</sub> Hdbd.	
<b>N</b> Drawer Frt/Bk (2)	7 <sup>7</sup> / <sub>8</sub> x 22 <sup>1</sup> / <sub>8</sub> - 1 <sup>1</sup> / <sub>2</sub> Ply.	
<b>O</b> Drawer Sides (2)	7 <sup>7</sup> / <sub>8</sub> x 13 <sup>1</sup> / <sub>4</sub> - 1 <sup>1</sup> / <sub>2</sub> Ply.	
<b>P</b> Drawer Bottom (1)	12 <sup>3</sup> / <sub>4</sub> x 22 <sup>3</sup> / <sub>8</sub> - 1 <sup>1</sup> / <sub>4</sub> Hdbd.	
(2) 6 <sup>1</sup> / <sub>2</sub> " Utility Pulls		
(12) 1 <sup>1</sup> / <sub>4</sub> "-20 Threaded Inserts		
(2) 1 <sup>1</sup> / <sub>2</sub> " Continuous Hinges, cut to 14" (w/ Screws)		
(2) 3 <sup>3</sup> / <sub>8</sub> "-dia. Rare-Earth Magnets w/Cups, Washers, and Screws		

Source Information:  
Knobs from McMaster.com, #1373T57, #1373T58

Magnet hardware from LeeValley.com, #99K3203 (3<sup>3</sup>/<sub>8</sub>" magnet), #99K3252 (3<sup>3</sup>/<sub>8</sub>" cup), #99K3262 (3<sup>3</sup>/<sub>8</sub>" washer), #99K3103 (1<sup>1</sup>/<sub>2</sub>" magnet), #99K3253 (1<sup>1</sup>/<sub>2</sub>" cup), and #99K3263 (1<sup>1</sup>/<sub>2</sub>" washer)

**Note:** Cutting diagram found on page 6





