



Woodsmith **PLANS**

# ADJUSTABLE TENON JIG



# ADJUSTABLE TENON JIG

*This jig takes versatility up a notch. It holds a workpiece vertically or at an angle and adjusts to fit any rip fence.*



**M**ost shop-built tenon jigs slip over the rip fence to cut a tenon on the end of a workpiece. It's a simple way to cut smooth, accurate tenon cheeks. The trouble is once you build the jig, there's no way to adjust the fit if changes in humidity make it too loose or too tight. And you're locked in to one rip fence.

The tenon jig that's pictured above solves both of these problems. It adjusts to fit any fence up to 4¾" wide. And it adds a few other benefits.

▲ **Separate Stops.** The vertical stop can be replaced to support a workpiece at an angle.

Like most tenon jigs, this one holds a workpiece vertically so it's safe and easy to make a cut. Then when you need to hold a workpiece on a 45° angle, to cut a splined miter for instance, you can add an alternate angled stop (inset photo on page 1). With all these features, cutting perfect tenons is safe and hassle-free.

**HOW IT WORKS.** The tenon jig isn't all that complicated. A front and back fence ride along the rip fence. A horizontal support has slots cut in it and connects the two fences — making it easy to sandwich the jig around any rip fence. There are also a few stops that can be positioned at various angles. They support your workpiece for any type of tenon cut.

### FRONT FENCE

I started building the jig by cutting a piece of 3/4" MDF to size for the front fence. There's a bit of work to do to prepare this piece for the features that will be added later.

**DRILL THE HOLES.** First, you need to drill a series of holes to attach a hold-down in a variety of positions for different size workpieces.

The other holes you see in Figure 1 will be used to attach the stops at either 90° or 45°. The locations need to be precise. So you can drill

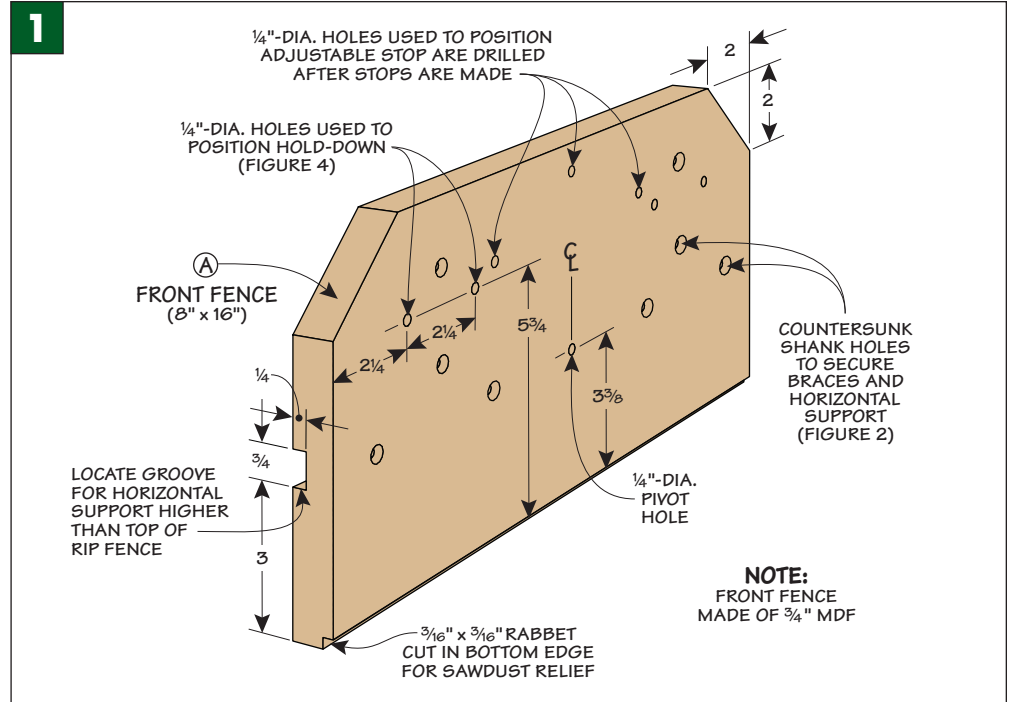

the pivot hole (that's used for all the angles) now, but you'll want to hold off on drilling the three positioning holes until the jig is assembled.

Once that's complete, cut a rabbet in the bottom edge for dust relief and a groove on the inside face. The groove is used to locate and attach the horizontal support. Just make sure it's located high enough to allow the horizontal support to clear

your rip fence. Then, you can finish up the front fence by knocking off the top outside corners.

### HORIZONTAL SUPPORT

The next piece to work on is the horizontal support. Here again, you can start by cutting a piece of 3/4" MDF to final size. Then, you'll need to cut the two slots, which make it possible to adjust the jig for any rip fence up to 4 3/4" wide. I took the piece to the router table to cut the slots.

**ASSEMBLY.** At this point, you're ready to glue and screw the horizontal support in the groove. To ensure the front fence stays square, I also added a couple of right angle braces, as shown in Figure 2.

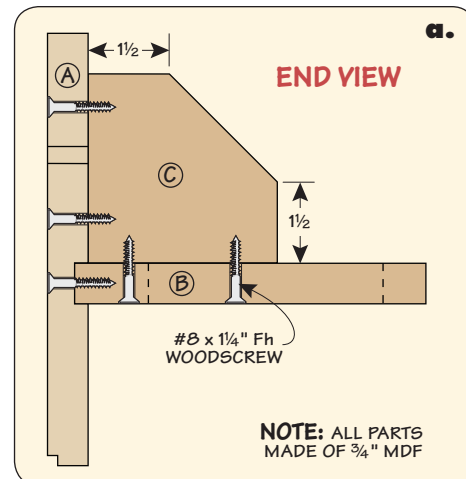
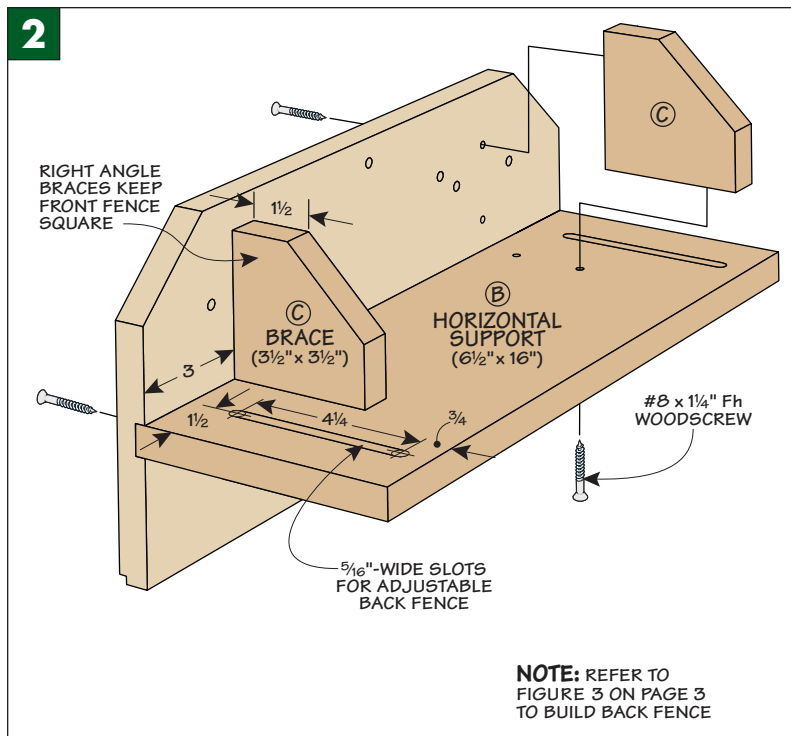

## Adjustable Fence & Stops

Once you've attached the horizontal platform to the front fence, you're ready to make the back fence and the stops. These pieces are fairly simple, but they give the jig all of its adjustability and accuracy.

### ADJUSTABLE BACK FENCE

The back fence is just a thick piece of MDF with a couple of hanger bolts in it. The hanger bolts fit into the slots cut in the horizontal support. This allows you to sandwich the front and back fences of the jig around your rip fence.

To make the back fence, start by gluing up two oversized pieces of MDF, and then trim them to size, as you see in Figure 3.

**ADD HANGER BOLTS.** Then you'll need to locate the pilot holes for the hanger bolts. The important thing to keep in mind is that the holes match up with the spacing of the slots in the horizontal support. After drilling a hole in each end, you can install the hanger bolts. To see how I did this, take a look at the left margin.

Now the back fence is complete. So go ahead and put the pieces together by positioning the hanger bolts in the slots in the horizontal support and locking them in place with washers and knobs.

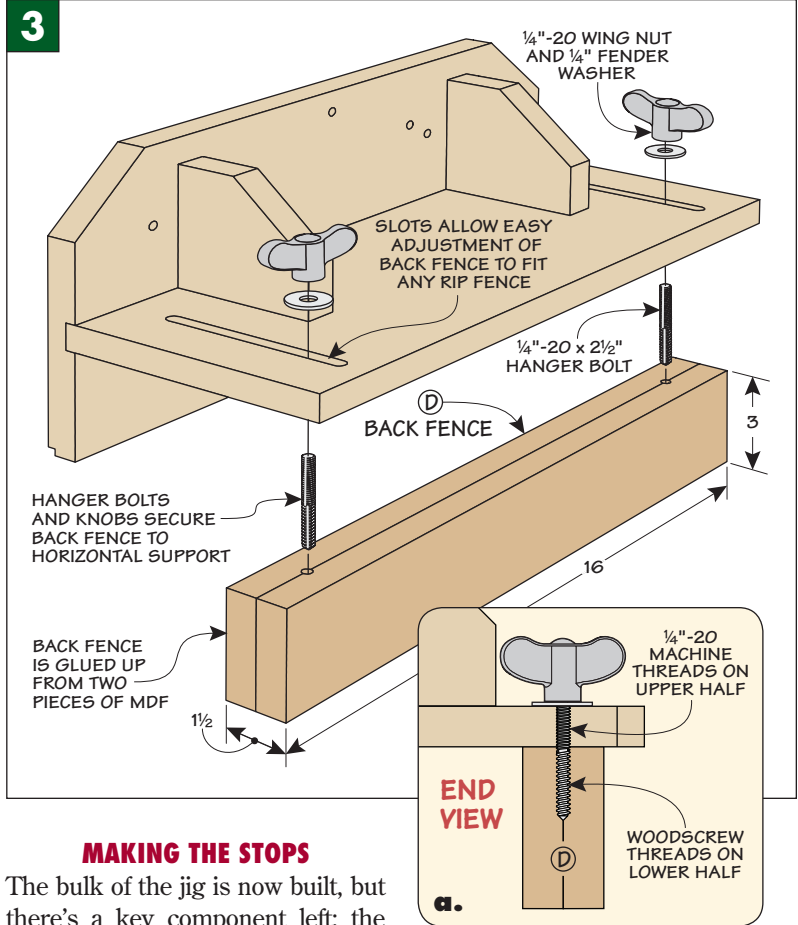

### MAKING THE STOPS

The bulk of the jig is now built, but there's a key component left: the adjustable stops. You'll need to make separate stops for each of the angles: 90°, 45° forward, and 45° backward. With the appropriate stop attached to the front, you'll be able to support your workpiece securely.

Each stop is simply a piece of 5/8\"/>

drilled into it. The lower hole will slip over a hanger bolt, which you'll install in the front fence. The upper hole allows you to position the stop at the various angles.

**THREE STOPS.** When a stop is positioned on the front fence, its bottom edge should be just above the surface of the table. That's easy when the stop is in the 90° position. But for the two stops you're going to use on the 45° angles, you'll have to cut a bevel on the bottom — and make different stops to angle forward and backward. This provides full support for the workpiece and prevents chipout when using the jig.

It's a good idea to make several stops for each angle right away. You'll find that the extras come in handy when working with different blade heights. And they tend to get chewed up pretty quickly.

**DRILL THE HOLES.** If you haven't done so already, drill two holes in each stop, as shown in Figure 4. Just make sure the holes are the same distance apart on each one.



▲ **Install Hanger Bolts.** Lock two nuts together to make it easy to drive hanger bolts into place.



▲ **Wide Fence.** Slots cut in the horizontal support allow you to adjust the back fence of the jig to fit your rip fence for a smooth sliding fit.



▲ **Narrow Fence.** There's no need to build a second jig for a narrower fence. The jig adjusts to fit them all.

**ESTABLISH ANGLES.** The stops will be attached to the front fence at the top with a hex bolt and knob, so they're easy to take off and switch out. But before you can attach any of the stops, the 90° and 45° angle positions must be established on the front fence. The box below shows a simple way to do this.

Note: To maintain an accurate angle when making additional stops (after the holes are drilled in the front fence), you'll need to use the jig to locate the holes.

**ADD A HOLD-DOWN.** Finally, you'll want to ensure your workpiece stays tight against the stop and front fence as you make a cut. To do this, you'll just need to add a hold-down. I decided to use a commercial hold-down, which can be bolted to the front fence with a carriage bolt.

### USING THE JIG

Once you've added the hold-down, your tenon jig is ready to be put to use cutting tenons, making splined miters, or for other shop tasks.

As I mentioned earlier, you just need to sandwich the front and back fences of the jig around your rip fence so that it will slide smoothly, and tighten the knobs. Then, your workpiece can be secured in position with the hold-down.

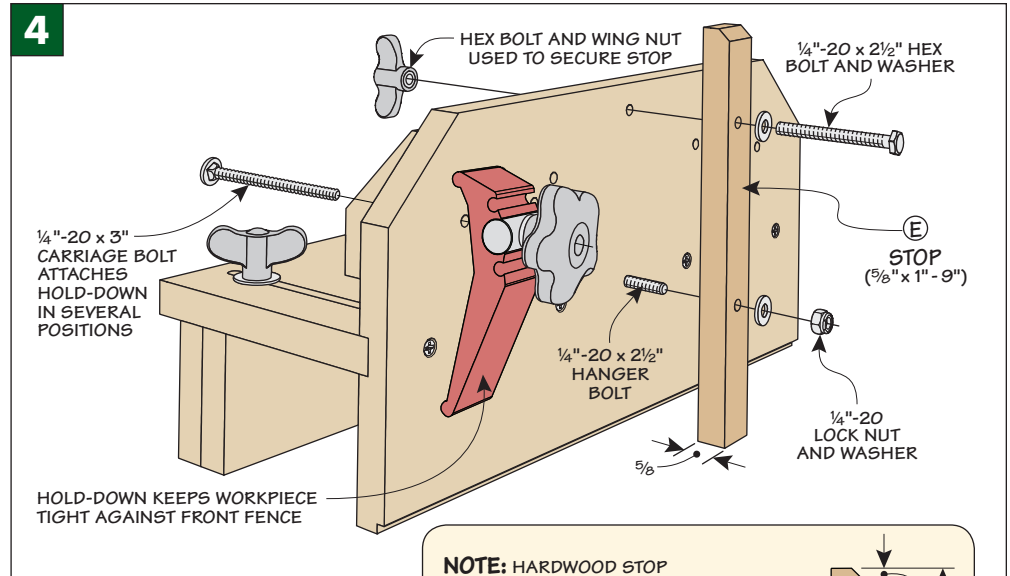

But before you actually turn on the saw and start using the jig, there's one other thing I'd like to mention. After completing a cut, you'll want to be careful to slide the jig back far enough from the blade so that when you release the hold-down, it doesn't inadvertently swing down into the spinning blade. Other than that, you should be good to go.

This tenon jig is certainly a worthwhile addition to your shop. With its two-fold adjustability — both to fit your rip fence snugly and to angle the stop — this jig will have you cutting top-notch tenons in no time.

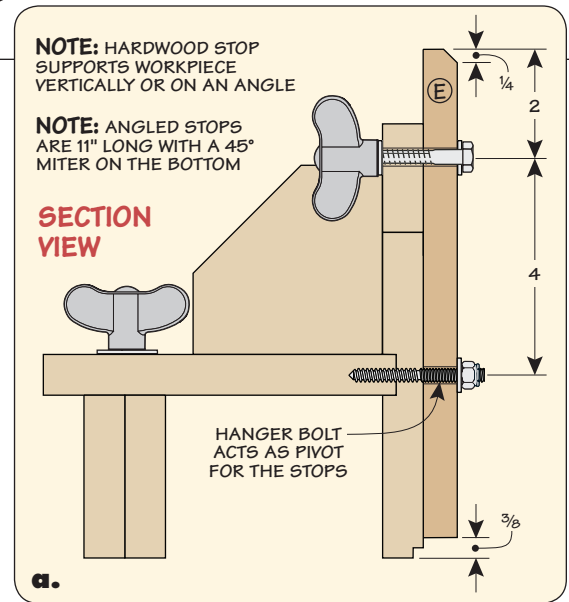

## SETTING UP THE STOPS

Having the stops positioned at a perfect 90° or 45° angle is the key to great results when using this jig. So it's important to position and drill the holes in the front fence accurately.

To do this, set the jig upright on your table saw and secure the stop to the front fence with a hanger bolt. Using a drafting triangle, position the stop at a 90° angle (first photo at right). Then you can simply drill through the hole in the stop and through the front fence.

To locate and drill the holes for each of the 45° positions, switch to a stop with the appropriate bevel, and repeat the process, like you see in the far right photo.

