



Woodsmith **PLANS**

DRILL BIT STORAGE



DRILL BIT STORAGE



Like many woodworkers, I keep my drill bits and accessories next to the drill press. After all, that's where I use them most often.

The only problem is that I frequently need to drill holes somewhere else, like at the bench or in the back yard. So I end up carrying a handful of bits back and forth.

That's why I built this simple storage system. It's made up of four individual hangers that organize my drill bits and accessories. To provide easy access to the bits when I'm using the drill press, the hangers hook onto a wall-mounted cleat, as shown in the photo on page 2. If I need to take the bits with me, I just lift one of the hangers off the cleat.

TWO TYPES OF HANGERS. Since I have several kinds of drill bits, I made two different types of hangers. Two racks hold my brad point bits, Forstner bits, and spade bits. And there are two bins for my twist bits, combination bits and sanding drums.

RACKS

I began by making the two racks. If you take a look at Figures 1 and 1a, you'll see that each rack is shaped like a mini I-beam with storage on each side for bits. A wood block attached to the front end of the rack adds rigidity, plus it provides a mounting surface for a handle.

I-BEAM. Each of the I-beams consists of a 1/4" hardboard core that's sandwiched between a top and bottom made of 1/2"-thick hardwood strips. (I used maple.)

These strips are identical in width (3"), but the top is 5/8" longer than the bottom. This creates an overhanging lip that extends past the end of the rack. Notice in Figure 1b that there's a slot in this lip that provides a way to hang the rack on a metal rail attached to the cleat.

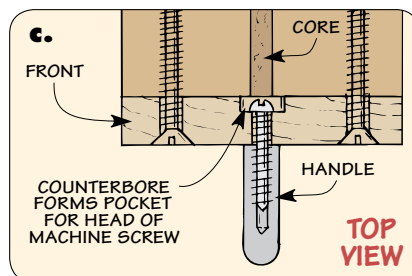
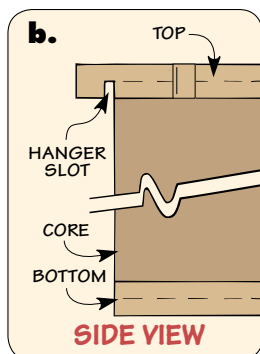
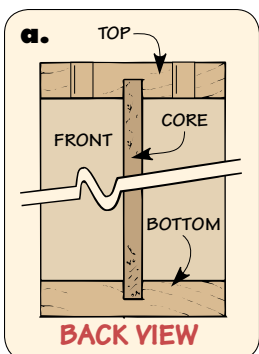
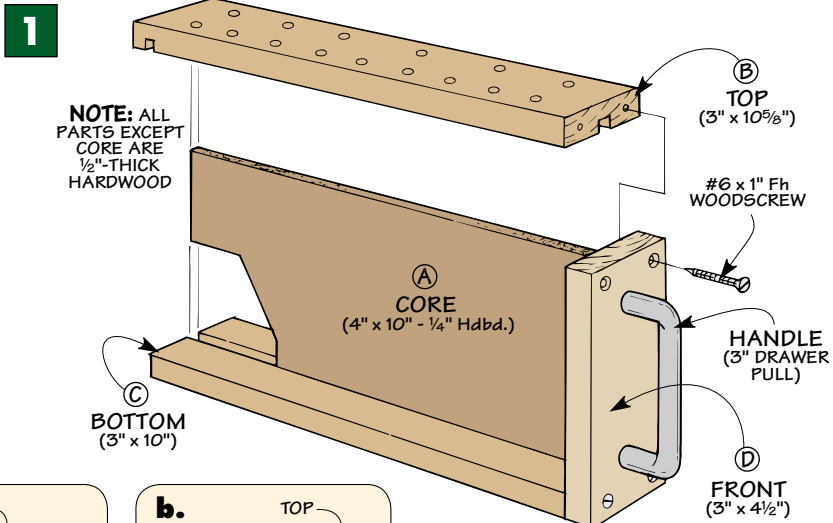

The slot is formed by cutting a dado near one end of each top piece. To cut the dado the same distance from the end in each piece, I used the setup shown in Figures 2 and 2a. Start by locking the fence $\frac{1}{2}$ " from the inside of the blade. Then butt the end of the workpiece against the fence, and use the miter gauge to push it across the blade.

GROOVE. Next, cut a groove in the top and bottom to accept the hardboard core. For a friction fit, "sneak up" on the final width of the groove, as shown in Figures 3 and 3a.

To do this, lock the rip fence in place so the saw blade is roughly centered on the width of the workpiece. Then make two passes, turning the workpiece end for end between each one. At this point, check the fit of the core piece in the groove. If it fits too tightly, nudge the fence away from the blade and repeat the process.

DRILL HOLES. The next step is to drill holes in each top piece so you can slip bits in and out. When laying out these holes, be sure to allow for some finger room between the bits.

Also, to make it easy to remove bits (or put them back in), I drilled each hole $\frac{1}{32}$ " larger than the shank of the bit that fits in it. Note: To hold my longest brad point bit, I drilled a single hole directly into the bottom of one rack (photo below).

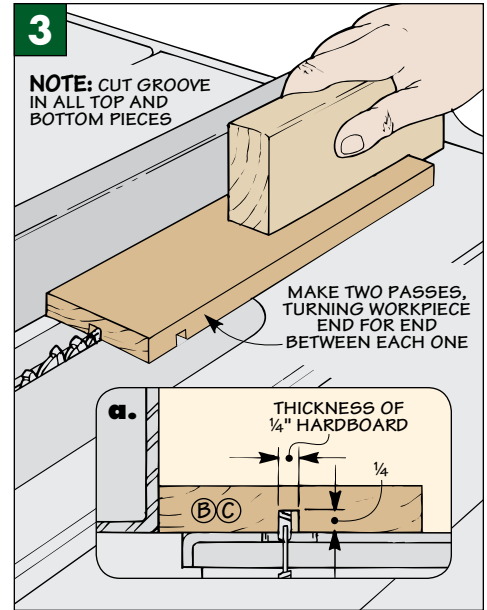
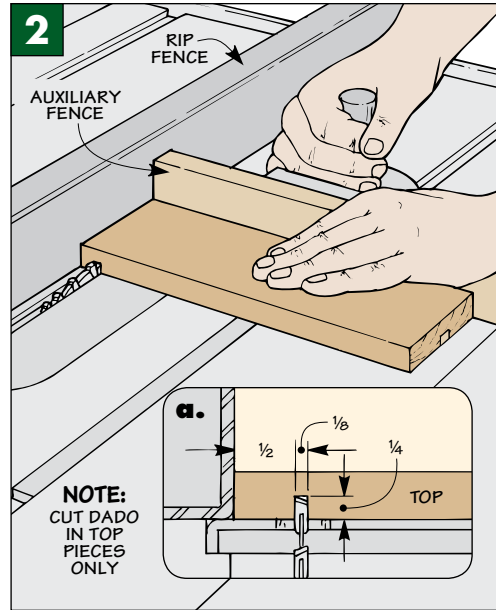

FRONT. Now you're ready to add the front piece for each rack. It's a $\frac{1}{2}$ "-thick hardwood block with a handle attached for easy carrying. I used a drawer pull as a handle and drilled a couple of counterbored shank holes for the machine screws that hold it in place. This allows the front of the rack to fit tightly against the end of the core piece (Figure 1c).

ASSEMBLY. Install the handle, and glue up the three pieces that form the I-beam. Then simply attach the front with glue and screws.

RISER BLOCKS. At this point, all that's left is to add a riser block to both

sides of each rack. These are scrap pieces of "two-by" material with a series of holes to hold the bottom ends of the bits (Figure 4). Note: I planed the stock to a thickness that allowed the riser blocks to fit flush with the outside of the rack.

To provide easy access to the bits, I wanted them to stick up an equal amount. So in order to align the tips of my brad point bits, I used a band saw to cut "stair steps" in that riser block. As for my Forstner bits, it was just a matter of ripping a block to width and gluing on one "step" for my shortest bit. The blocks for my spade bits are identical in width.

Now it's just a matter of drilling holes in the blocks that align with the holes in the top of the rack. Then glue the blocks in place.

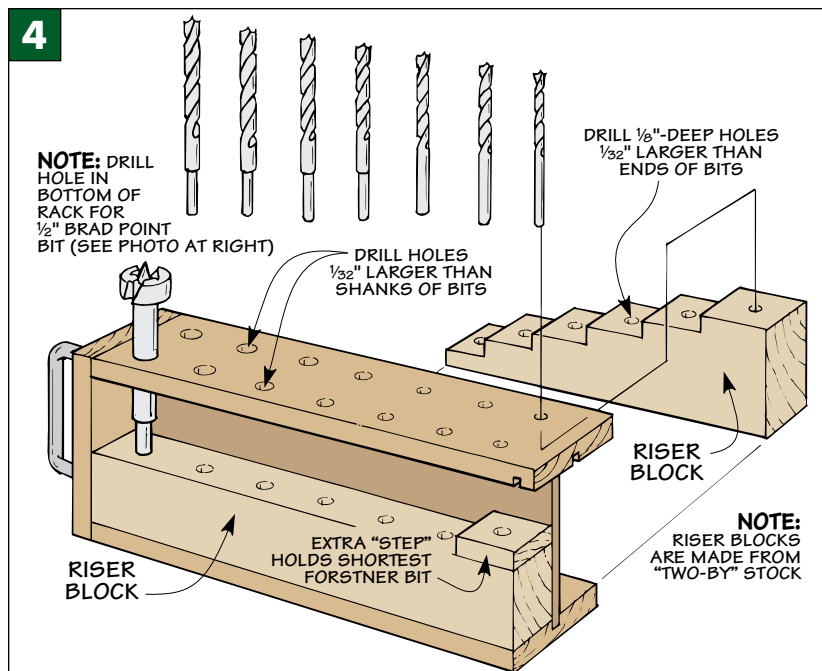

▲ **Removeable Hangers.** Each hanger hooks onto a metal rail attached to a wall-mounted cleat. To drill a hole in a project at the bench (or around the house), simply lift the hanger off the rail and take the bits with you.

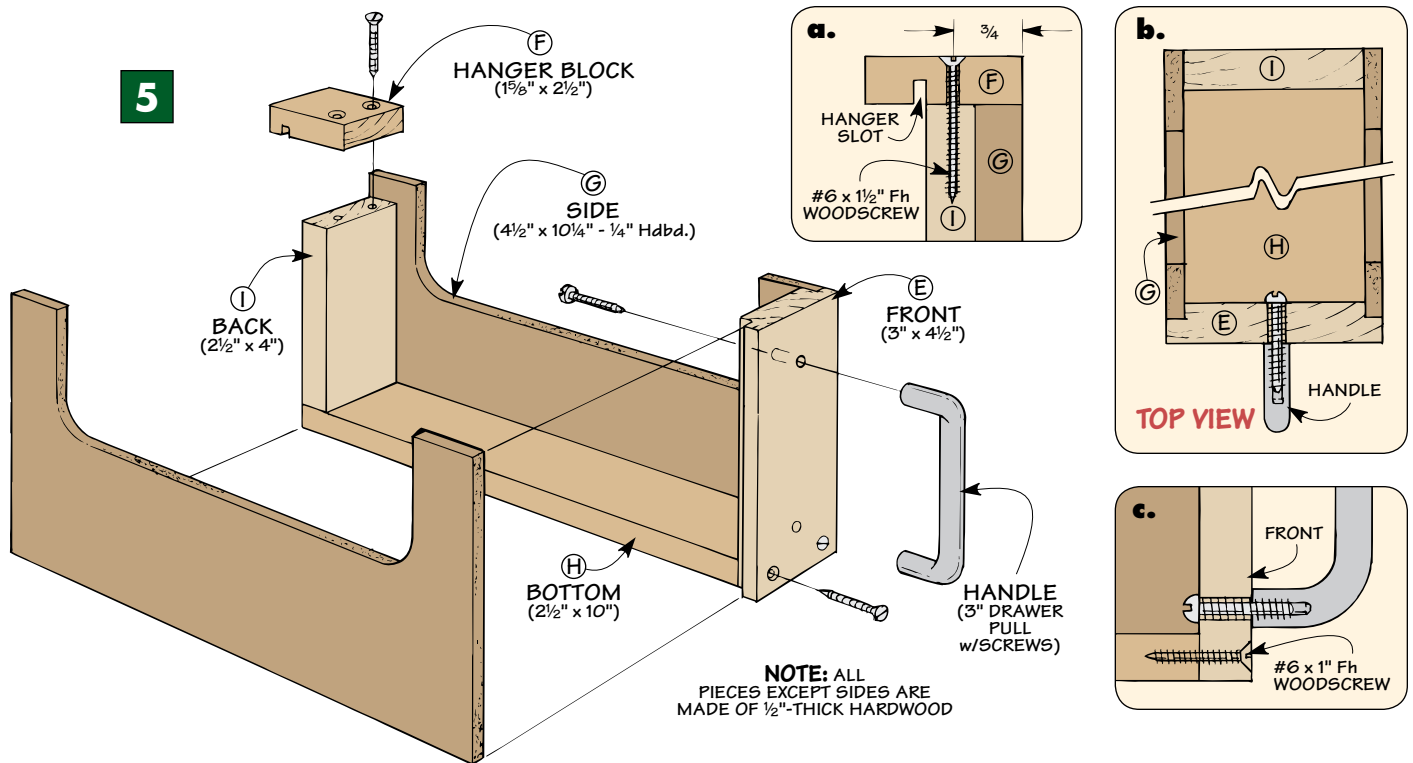

Storage Bins

In addition to the two racks, I made a couple of storage bins to hang on the cleat. As you see in the photo on page 4, each bin is a narrow container that can be used to hold a variety of drill bits and accessories.

SIZE. As with the racks, you may want to modify the size of the bins depending on what you plan to put inside them. (I made the bins the same size as the racks.)

CONSTRUCTION. It won't take long to build the bins. As Figure 5 shows, each bin is an open box that's made up of a hardwood front, back, and bottom piece and a pair of hardwood sides. Also, a short hanger block attached to the back provides a way to hook the bin on the cleat.

FRONT. Like the racks, the front of each bin is made from 1/2"-thick hardwood. But this time, the front is

rabbeted on each edge to hold the sides of the bins (Figure 5b).

This requires working with a fairly small piece. To cut it safely, I used a rabbet bit mounted in the router table (Figures 6 and 6a).

Setting up the router table is a simple two-step process. First, set the fence so the width of the rabbet will match the thickness (1/4" hardwood). Second, adjust the height of the bit to cut a 1/4"-deep rabbet.

Now turn on the router, place the edge of the workpiece against the fence, and use a push block to feed it across the bit (Figure 6).

HANGER BLOCKS. Once the front pieces are completed, you can turn your attention to the hanger block for each bin. It's a short, 1/2"-thick hardwood block with a slot in the bottom that hooks onto the rail on the cleat (Figures 5 and 5a).

The size and location of this slot are the same as the one in the top of each rack (Figure 7a). But again, the hanger blocks are fairly small. So it's best to start with an extra-long piece and cut a dado in each end to form the slot (Figure 7). Then trim each hanger block to length.

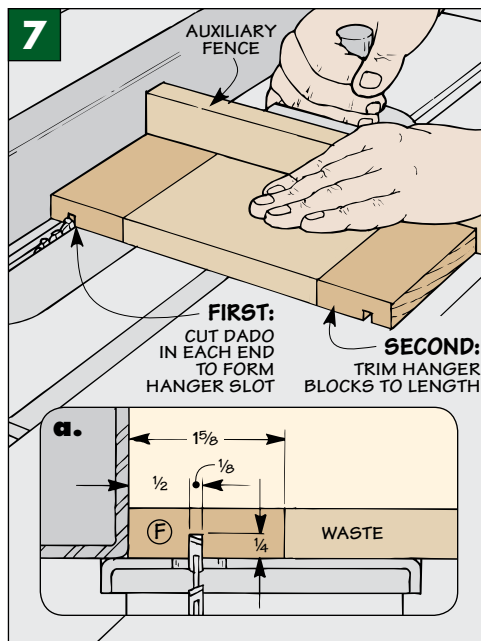
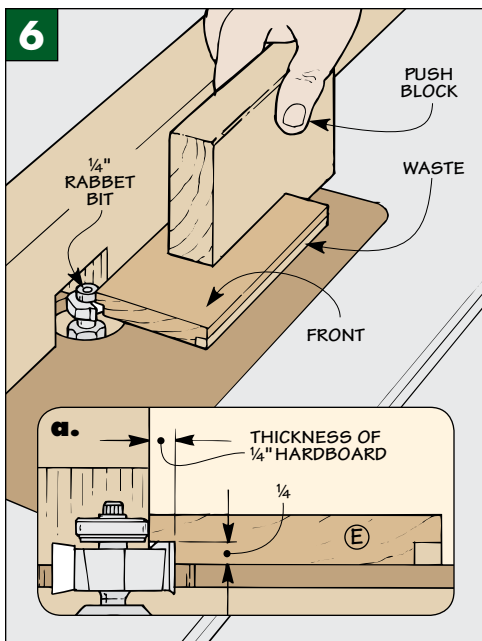

ADD THE SIDES. At this point, it's time to add the sides of the bins. To see at a glance what's inside the bins, the sides are scooped out to form a long, deep notch. It only takes a few minutes to make these notches.

After cutting blanks for the sides (two for each bin), lay out the notch and use a band saw (or jig saw) to cut about 1/8" to the waste side of the line. The rest of the material can be removed using a drum sander chucked in the drill press, as illustrated in Figure 8.

To sand the entire thickness of the workpiece, you'll need to "bury" the lower part of the drum sander in a hole that's cut in an auxiliary table. (I attached a piece of plywood to the drill press table.) You'll also want to locate a straight piece of wood to use as a fence. After notching it to fit around the drum sander, position the fence to sand to the desired depth and clamp it in place.

To produce identical notches, it's a good idea to attach the two sides with double-sided tape. Then, after turning on the drill press, start at the right end of the notch and push the workpiece into the drum sander until the "feet" contact the fence.

Slowly feed the workpiece from left to right to sand the edge smooth.

BOTTOM & BACK. To complete each bin, I added a hardwood bottom and back. These pieces are assembled with ordinary butt joints. But first, be sure to pre-drill holes in the front for the machine screws that hold the handle (Figure 5c). Then assemble the bins with glue and screws.

► One of the simplest ways to organize drill bits and accessories is to store them in wood blocks that fit inside the bins.

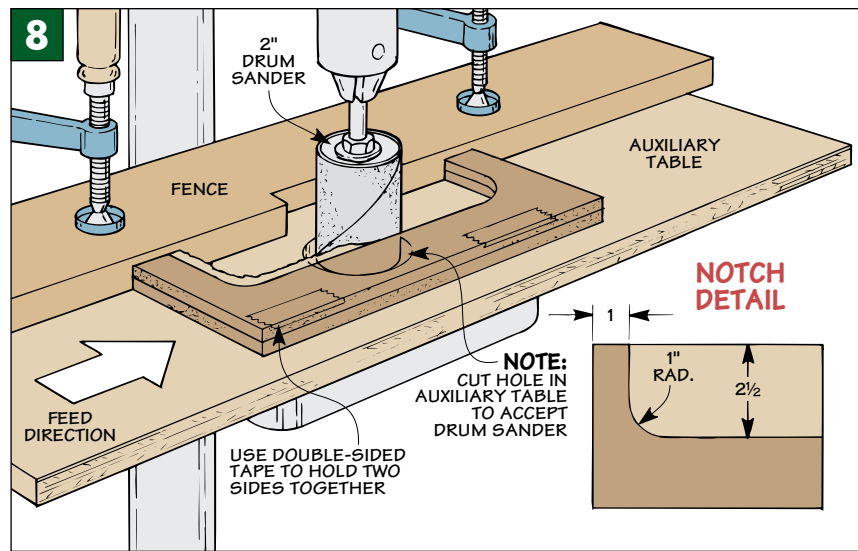
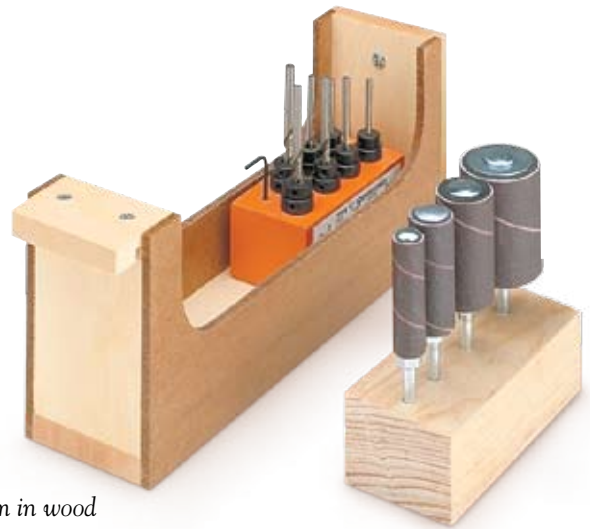

WALL-MOUNTED CLEAT

As you can see in the photos below, the racks and bins hang on a simple cleat that mounts to the wall.

To provide rigid support, the cleat consists of two parts: a hardwood mounting plate and a rail made from aluminum

angle bracket (Figure 9). After drilling three shank holes in the rail, it's simply screwed to the top edge of the cleat.

DETERMINE LENGTH. Just a note about the length of the cleat. To hold all four hangers, the cleat shown is 12" long.

Since I planned to screw the cleat directly to a wall covering made of fir plywood, I didn't have to worry about the screws hitting the wall studs. If you plan to fasten the cleat to wallboard, be sure to make it long enough to anchor it in the studs.

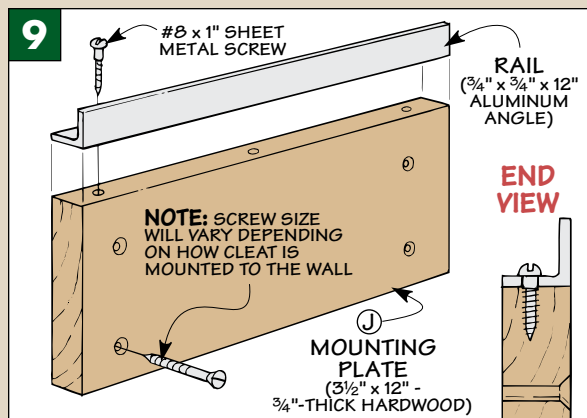

▲ **Cleat.** A two-part cleat that's made up of a hardwood mounting plate and a metal rail lets you hang each of the racks (left) and bins (right) on the wall. Just be sure to anchor the cleat securely to the wall.