



Woodsmith **PLANS**

PEGBOARD SYSTEM



PEGBOARD SYSTEM

Here's a tool rack that takes a different approach to using common pegboard. You can customize it to fit your needs and your tools.



Almost every workshop has a sheet or two of pegboard on the wall, plus an assortment of wire hooks that hold the usual items — screwdrivers, pliers, hammers, and other hand tools.

FALLING HANGERS. One thing that has always bothered me about pegboard storage is that almost every time I reach for a tool, the hook comes off with it or falls to the floor.

To avoid this, I came up with a whole new system of tool racks and storage units that stay put on pegboard. The system uses common L-hooks, which are available at any

hardware store or home center. These hooks are screwed to the back of each storage unit. (For more on this, see the box on page 4.)

WASTED SPACE. Another thing that bothers me about traditional pegboard systems is how they waste space. They don't seem to hold as many tools as they should.

So when I designed this new system, I modified some common tool and clamp racks to make them more efficient. And I added adjustable shelves and drawers.

CUSTOMIZE IT. Though this system has a lot of handy features, the best

part is how easily it can be customized to fit your needs. You can add more shelves or drawers if you need them. And the L-hooks allow you to move things around easily to make them more convenient.

MATERIALS. This entire pegboard system is built with common materials found at most lumberyards or home centers. To build the frame, I used one six-foot 2x8 and a little less than a full sheet (4x8) of 1/4" pegboard.

For all of the shelves, drawers, and different storage units, I simply used pine boards, 3/4" plywood, and some small pieces of 1/4" hardboard.

Construction Details

Overall Dimensions: 36" x 72" x 6"

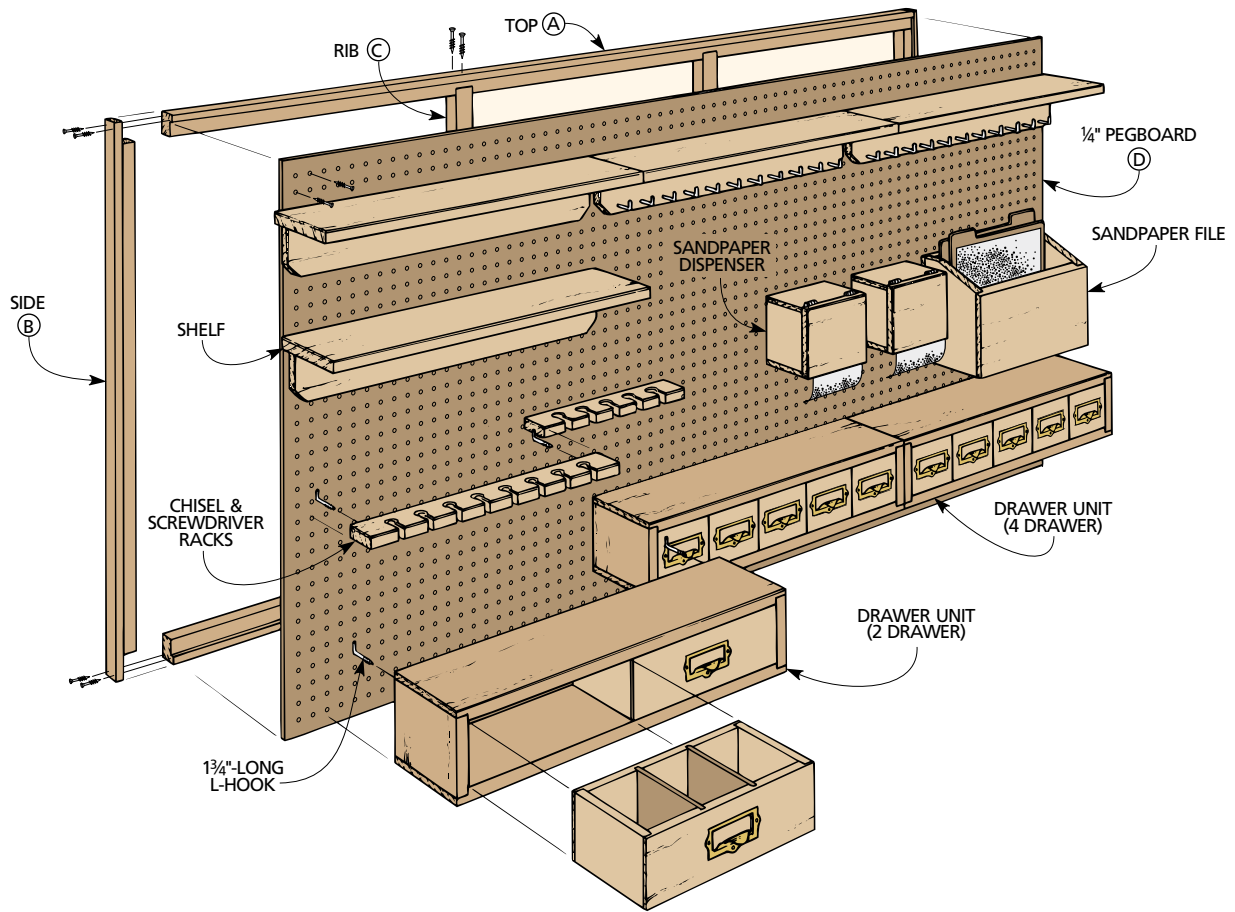

MATERIALS & HARDWARE

PEGBOARD FRAME

A	Top/Bottom (2)	1 1/2 x 1 1/2 - 71
B	Sides (2)	1 1/2 x 1 1/2 - 36
C	Ribs (2)	1 1/2 x 1 1/4 - 34
D	Pegboard (1)	1/4 pgbd. - 35 x 71

DRAWER UNIT

E	Frame Top/Bottom (2)	3/4 x 6 - 24
F	Frame Sides (2)	3/4 x 6 - 4 1/4
G	Frame Back (1)	1/4 hdbd. - 4 x 23
H	Drawer Sides*	1/2 x 3 7/16 - 5 1/2
I	Lg. Drawer Front/Back (4)	1/2 x 3 7/16 - 11 3/16
J	Sm. Drawer Front/Back (10)	1/2 x 3 7/16 - 4 7/16
K	Lg. Drawer Bottom (2)	1/4 hdbd. - 5 1/4 x 10 11/16
L	Sm. Drawer Bottom (5)	1/4 hdbd. - 3 15/16 x 5 1/4
M	Lg. Drawer Divider (4)	1/4 hdbd. - 2 15/16 x 5 1/4
N	Sm. Drawer Divider (5)	1/4 hdbd. - 2 15/16 x 3 15/16

SHELF

O	Shelf (1)	3/4 x 6 - 24
P	Back (1)	3/4 x 3 1/4 - 23

SANDPAPER DISPENSER

Q	Sides (2)	1/2 x 3 3/4 - 4 1/4
R	Door (1)	1/2 x 5 - 6

S	Top/Bottom (2)	3/4 x 4 1/4 - 6
T	Back (1)	1/4 hdbd. - 4 x 5 1/2

CHISEL & SCREWDRIVER RACKS

U	Chisel Rack (1)	3/4 x 2 1/4 - 12
V	Screwdriver Rack (1)	3/4 x 2 1/4 - 18

SANDPAPER FILE

W	Front (1)	3/4 x 6 1/2 - 12 3/4
X	Back (1)	3/4 x 8 - 12 3/4
Y	Sides (2)	3/4 x 5 1/4 - 8
Z	Bottom (1)	1/4 hdbd. - 4 5/8 x 11 3/4
AA	Dividers*	1/4 hdbd. - 9 3/4 x 11

CLAMP RACKS

BB	Top (1)	3/4 ply. - 4 x 12 1/2
CC	Back (1)	3/4 ply. - 3 1/4 x 12 1/2
DD	Supports (2)	3/4 ply. - 3 1/4 x 3 1/4

C-CLAMP RACK

EE	Back (1)	3/4 x 5 - 11
FF	Top (1)	1 1/2 - 2 1/4 x 5
GG	Dowels (4)	3/4-dia. x 4 1/4

PULL SAW & SQUARE HOLDERS

HH	Shelf (1)	3/4 x 3 1/2 - 8
II	Back (1)	3/4 x 1 1/4 - 7

- (16) #8 x 1 3/4" Fh Woodscrews
 - 5/32"-dia. x 1 3/4"-long L-hooks*
 - #4 x 3/8" Fh Woodscrews*
 - #6 x 1" Fh Woodscrews*
 - #8 x 1 1/2" Fh Woodscrews*
 - 1" wire brads*
 - Drawer pulls with label holders*
 - 1" x 1" butt hinges w/screws*
 - Hacksaw blade*
 - Toilet paper holder*
- *Quantities will depend on individual needs

Pegboard Frame

The frame that the pegboard hangs on is made from standard “two-by” lumber (1½" thick). I used ¼" pegboard instead of ⅛" pegboard because it will hold the heavy weight of the bins and shelves better.

FRAME. Start by cutting the top, bottom, and sides to a width of 1½" and to finished lengths (Figure 1).

Then you can cut the two reinforcing ribs to finished width and rough length. Also, rip them to finished thickness (1¼").

RABBET. To join the frame, first cut a rabbet on the inside edges of the top, bottom, and sides to hold the ¼" pegboard. To do this, I used a dado blade buried in an auxiliary fence on the table saw (Figure 2).

NOTCH. To join the sides to the top and bottom, cut a notch on both ends of each side (Figure 3). Cut these notches just wide enough to accept the top and bottom pieces.

DADO. After the sides are notched, the next step is to cut two dadoses in the top and bottom to hold the ribs, like you see in Figure 5.

ASSEMBLY. With the dadoses cut, the frame is ready to be assembled. To do this, first drill and screw the sides to the top and bottom (Figure 4).

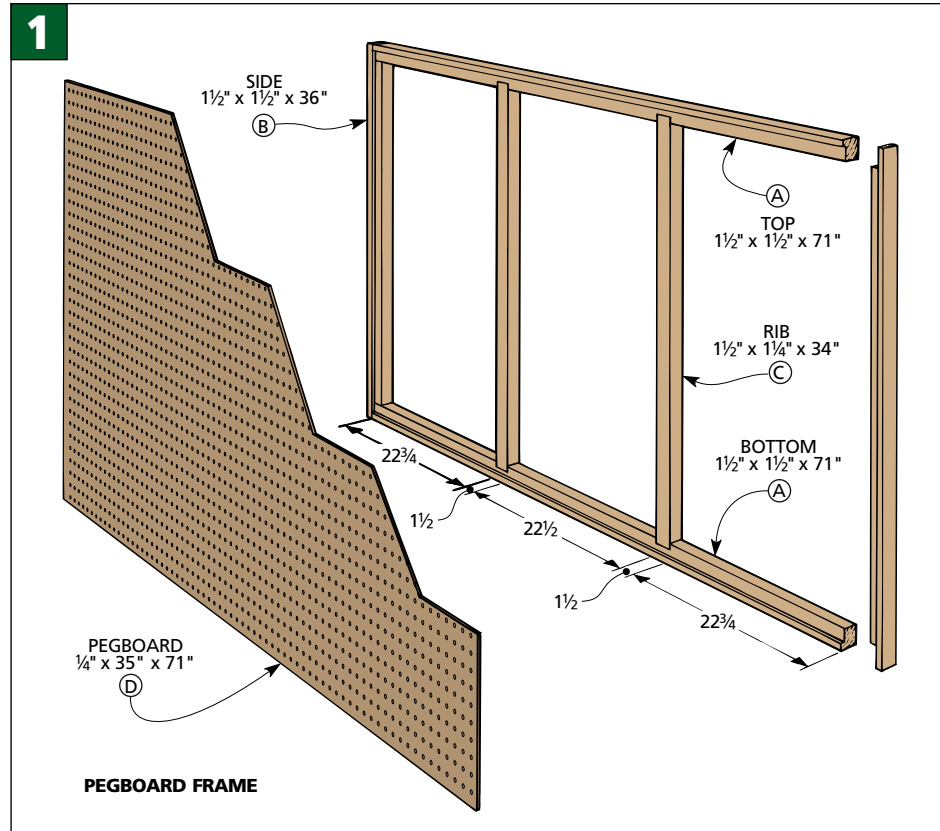

Then cut the ribs to finished length and screw them in place (Figure 5).

PEGBOARD. Once the frame is screwed together, cut the pegboard to fit between the rabbets. Cut the pegboard so the holes are about ½" from the edge (Figure 6). That way,

the L-hooks in the storage units won't contact the sides or ribs. And the units won't hang over the edge of the frame. It also allows you to screw the pegboard to the frame through the holes.

CHAMFER. Finally, rout an ⅛" chamfer around the outside edge (Figure 7).

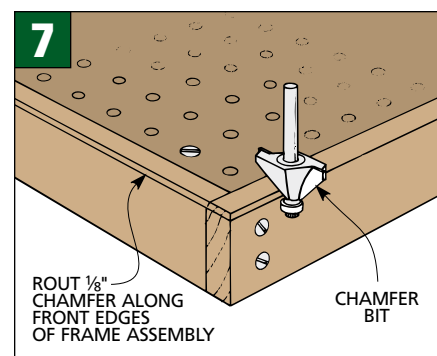
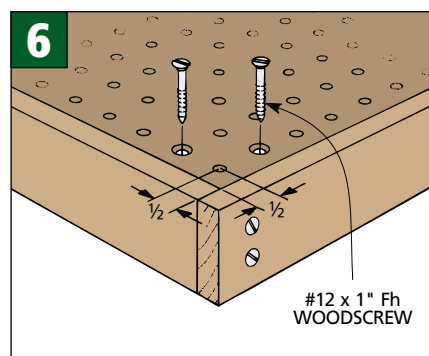
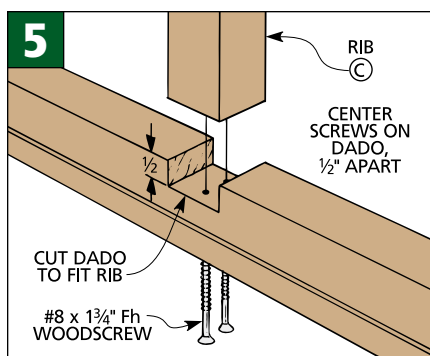
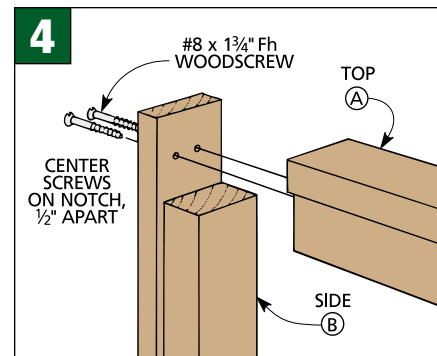
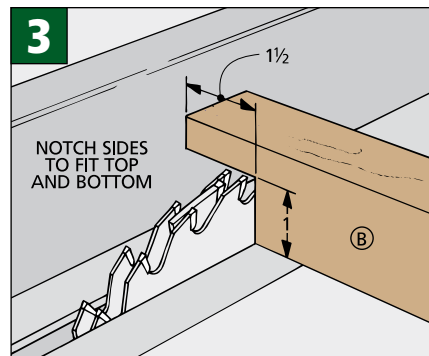
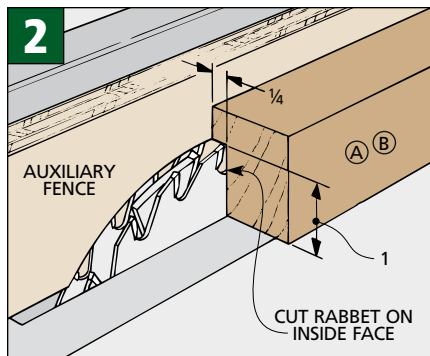



Drawer Unit

To help organize some of the hardware scattered throughout the shop, I decided to build five-drawer and two-drawer storage units.

The frames for both drawer units are identical. The only differences are the size and number of drawers.

FRAME. A frame consists of the top and bottom, two sides, and a back. Each is $\frac{3}{4}$ " pine, except for the $\frac{1}{4}$ " hardboard back (Figure 8).

To hold the back, a rabbet runs along the back edge of each piece (Figure 8a). Rabbets are also cut on either side of the top and bottom to hold the sides (Figure 8b).

Now glue and screw the top and bottom to the sides. Then cut the back to size and glue it in place.

Next, chamfer the top and bottom. Then screw three L-hooks into the back edge of the top. The box below shows how to install them so the unit hangs properly.

DRAWERS. The frames are ready for the drawers. I used $\frac{1}{2}$ "-thick stock for all the parts, except the $\frac{1}{4}$ " hardboard bottoms and dividers (Figure 9).

When building either size drawer, the basic approach is the same. There are only two differences — the lengths of the fronts and the backs, and the number of dividers.

To begin, cut the sides, fronts, and backs to size (Figure 9). Now cut a rabbet on the front and back pieces for the sides. Then cut a groove on the inside face of each piece for the bottom.

Next, cut $\frac{1}{4}$ "-deep dados for the dividers. On the larger drawers, cut the dados in the fronts and the backs. On the smaller drawers, cut them in the sides.

Now dry assemble each drawer to determine the size of the bottom and dividers (or divider). After they're cut to size, glue and nail the drawers together. Finally, I added a pull with a slot for a label card to each drawer.

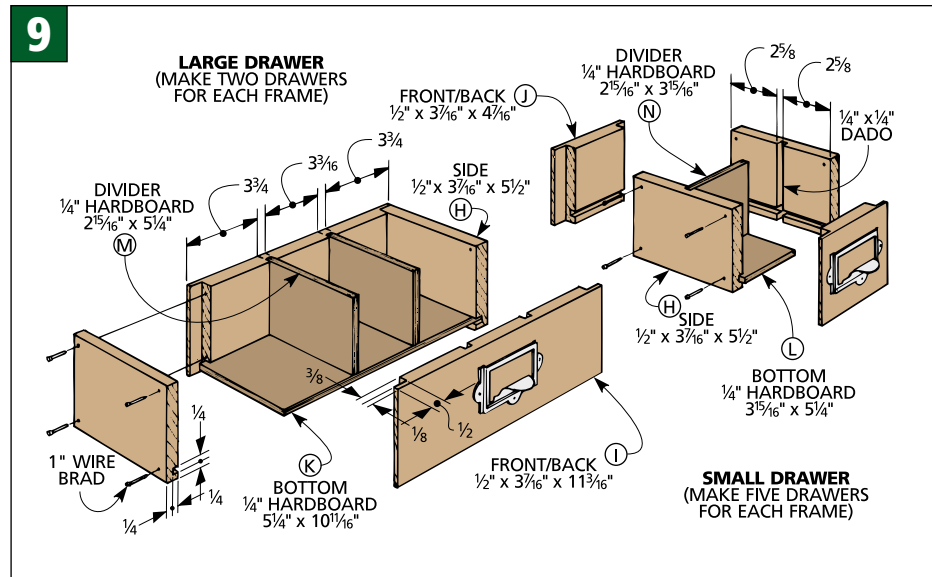
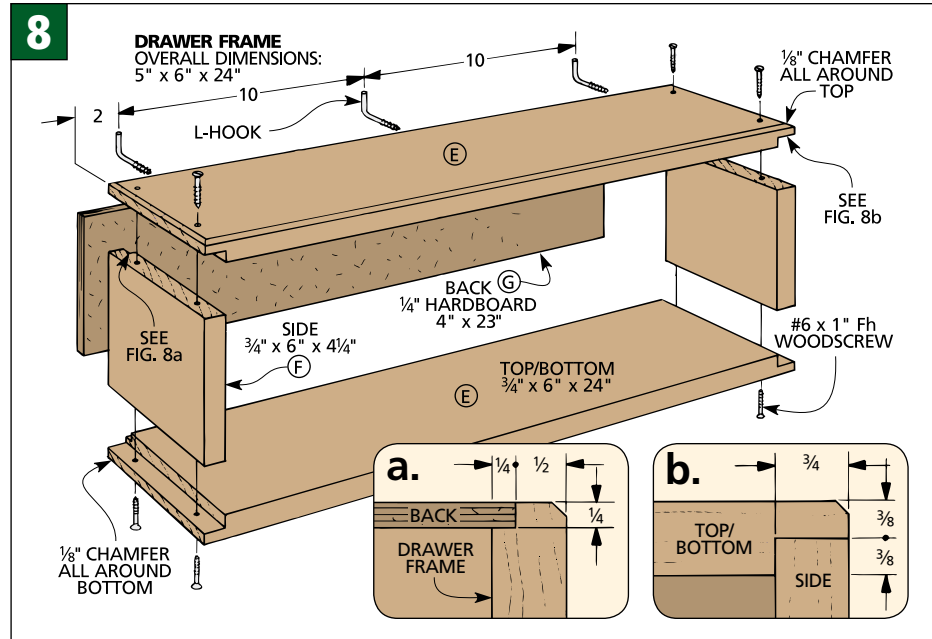

SHOP-TIP: L-HOOK SYSTEM

All of the storage units and shelves for this pegboard system hang the same way. They're perfect for this project because, unlike typical metal pegboard hooks,

it's almost impossible for them to fall out.

To use this system, first screw $1\frac{3}{4}$ "-long L-hooks to the back of each storage unit (drawing below left).

Then, to hang the unit, tilt it in the pegboard at a 45° angle (top photo at right).

As the unit is lowered and straightened, the hook pulls tight against the back of the pegboard (bottom photo at right).

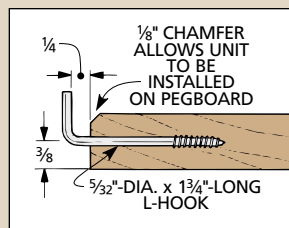



Shelf

When designing this pegboard system, I thought it would be a good idea to have a shelf for small items like glue bottles and wood filler.

The simplest shelf to build would have been a board with two mounting hooks screwed in the back. But to add more support to the shelf, I added a back (Figure 10).

Once I screwed the back in place, I realized it could be used for more than support. So I screwed L-hooks in the back near the bottom and used them for hanging hand tools (Figures 11 and 12).

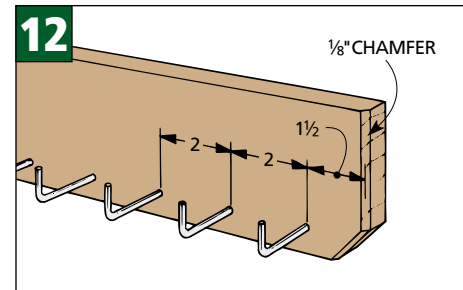
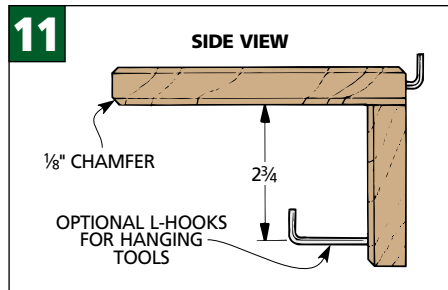
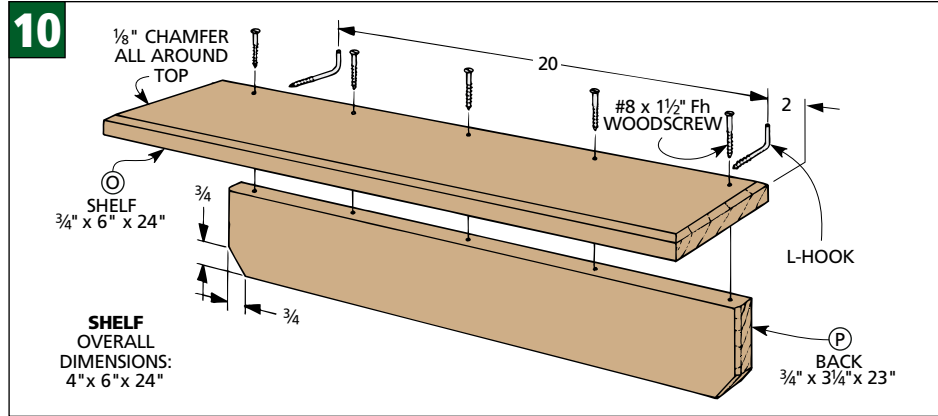

Sandpaper Dispenser

I use a lot of adhesive-backed sandpaper in the shop. When I realized that I go through about as many rolls of it as I do toilet paper, I thought to make a sandpaper dispenser using a toilet paper holder.

Each dispenser is built with 1/2 inch-thick stock for the sides and door. But I used 3/4 inch-thick stock for the top because it allowed me to screw



L-hooks into it (Figure 13). Because the top and bottom have the same size rabbets, the bottom is also 3/4 inch thick.

Before the parts can be assembled, several things have to be done. First cut 1/4 inch rabbets in the

top, bottom, and sides for the back (Figures 13 and 14). Second, cut mortises in the top for hinges (Figure 13). Drill a finger hole in the bottom to make it easier to tear off a piece of sandpaper (Figure 14). Then cut

a recess in the bottom edge of the door for a piece of a hacksaw blade to act as a paper cutter (Figure 15).

After drilling holes for the toilet paper holder (Figure 16), assemble the dispenser with glue and nails.

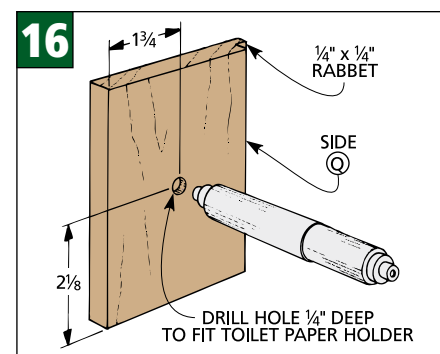
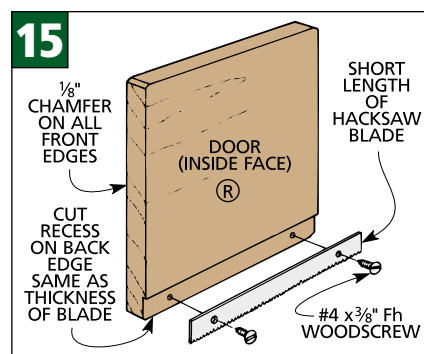
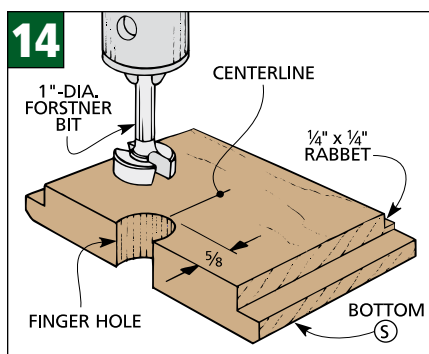
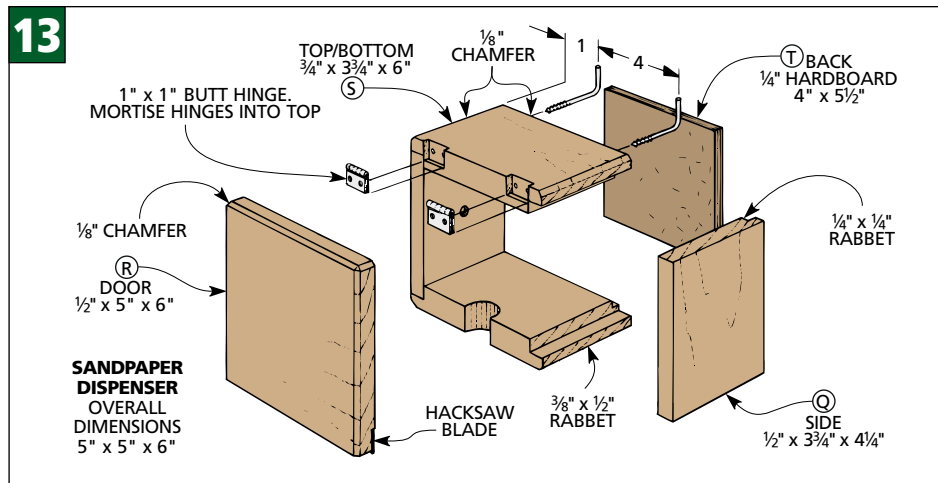

Chisel/Screwdriver Rack

The pegboard system wouldn't be complete without a rack for chisels and screwdrivers. Since not all screwdrivers and chisels are alike, use the ideas shown and customize them to fit your specific tools.

With many tool racks, you have to lift the tool to clear the hole in the rack, which means you can't put anything directly above it. Instead, these tool racks have slots in front of the holes, so you can pull the tools straight out.



When drilling a hole for a chisel, chamfer the top edge so the ferrule can't slip out (Figures 17 and 17a). When drilling for a screwdriver, counterbore the hole slightly larger than the handle so it sits down into the hole (Figures 18 and 18a).

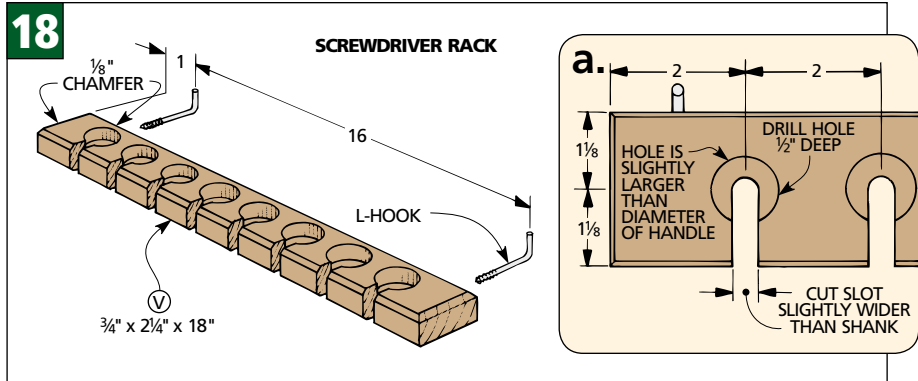
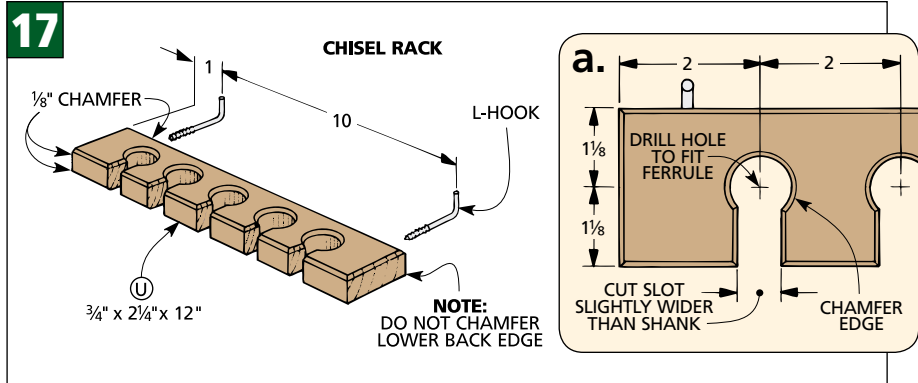

Sandpaper File

I've always had a hard time keeping sheets of sandpaper flat. They tend to curl up when the humidity changes. So, I made this system that keeps them flat and dry. It also lets me store them according to grit.

The sandpaper file is a pine box with an open top (Figure 19). Loose dividers made of 1/4 inch hardboard, similar to folders in a file cabinet, separate different grits of sandpaper and keep them flat (Figure 21).

To begin, cut a rabbet in the ends of the front and back pieces for the sides. Then cut a rabbet in the front and sides for the bottom.



To make it easier to get the sandpaper out of the file, I cut the sides at an angle on the band saw, and then bevel-ripped the top edge of the front on the table saw to match (Figure 20).

Once all the parts are glued and screwed together, install L-hooks in the back. Cut the dividers to shape with a file "tab" (Figure 21), and then label them for the grits you use.

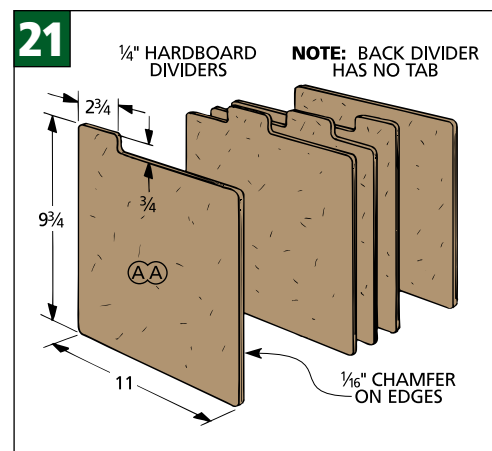
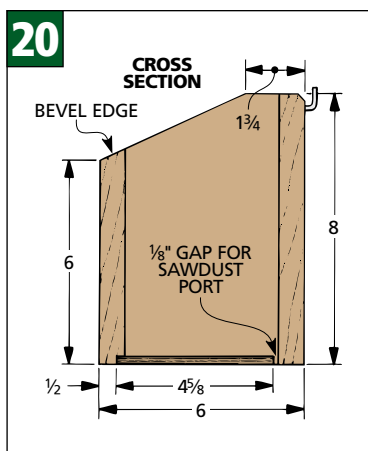
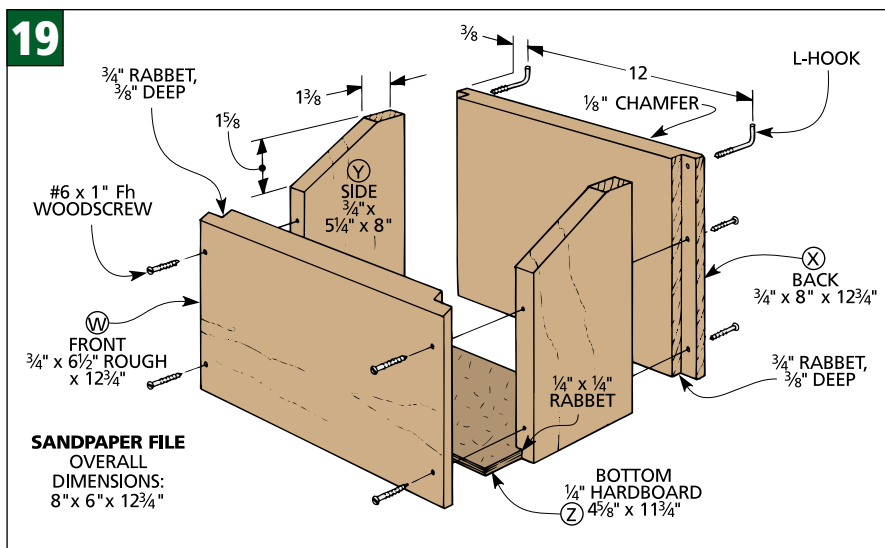

Clamp Racks

At this point, the pegboard system is equipped with quite a few storage options. But if you have some items that are still a little awkward to store (like clamps, saws, and squares), it's easy to make extra racks to hold them.

The rack you see here isn't shown in the main photo on page 1, but it's the perfect addition to keep clamps organized and accessible.

As you can see in Figure 22, the L-shaped rack is braced at each end by a triangular support. Each rack is the same size, but the slots are customized for different types of clamps.

All of the pieces are made from $\frac{3}{4}$ " plywood (although hardwood would work as well). I used scrap pieces that were too small for projects but too big to throw out.

I made each rack $12\frac{1}{2}$ " long. But they can be made any length that accommodates your clamps.

CUT PIECES. The first step is to cut a top, back, and two supports to size for each rack, like you see in Figure 22. Before assembling the racks, add L-hooks, as shown in Figure 22a.

SLOT LAYOUT. Next, lay out the slots for the clamps in each top piece. The detail drawings in Figure 22 show racks for the most common types of clamps. Note: Racks for pistol-grip clamps don't need slots.

CUT SLOTS. After the slots are laid out, you can start cutting them. I found the best way to do this is to drill a hole at the top of each slot first (Figure 23). Then the waste can be removed using the table saw. As Figure 24 shows, I attached an auxiliary fence to my miter gauge to support the workpiece and prevent the waste from kicking back.

ASSEMBLY. Once the slots are cut, the rack can be glued up. The top is clamped to the top edge of the back. Then the supports are added.

This rack takes care of storing long clamps. A rack for C-clamps is shown on the following page.

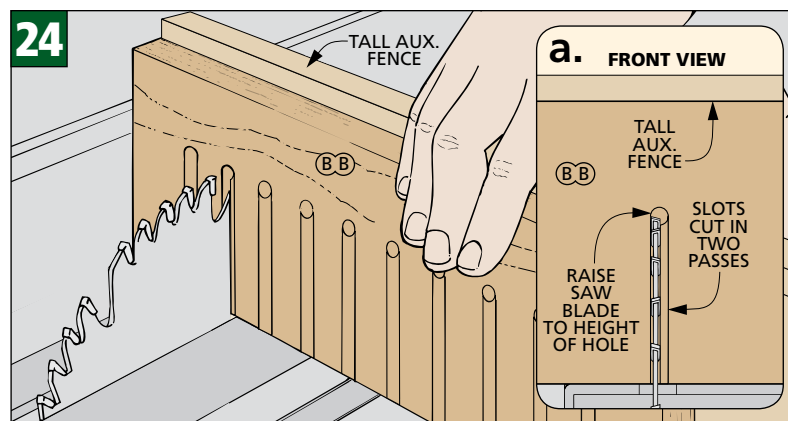
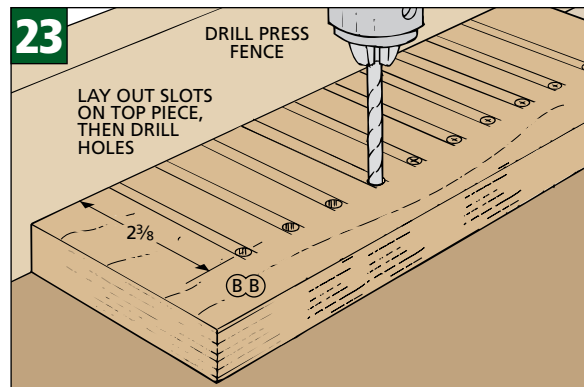
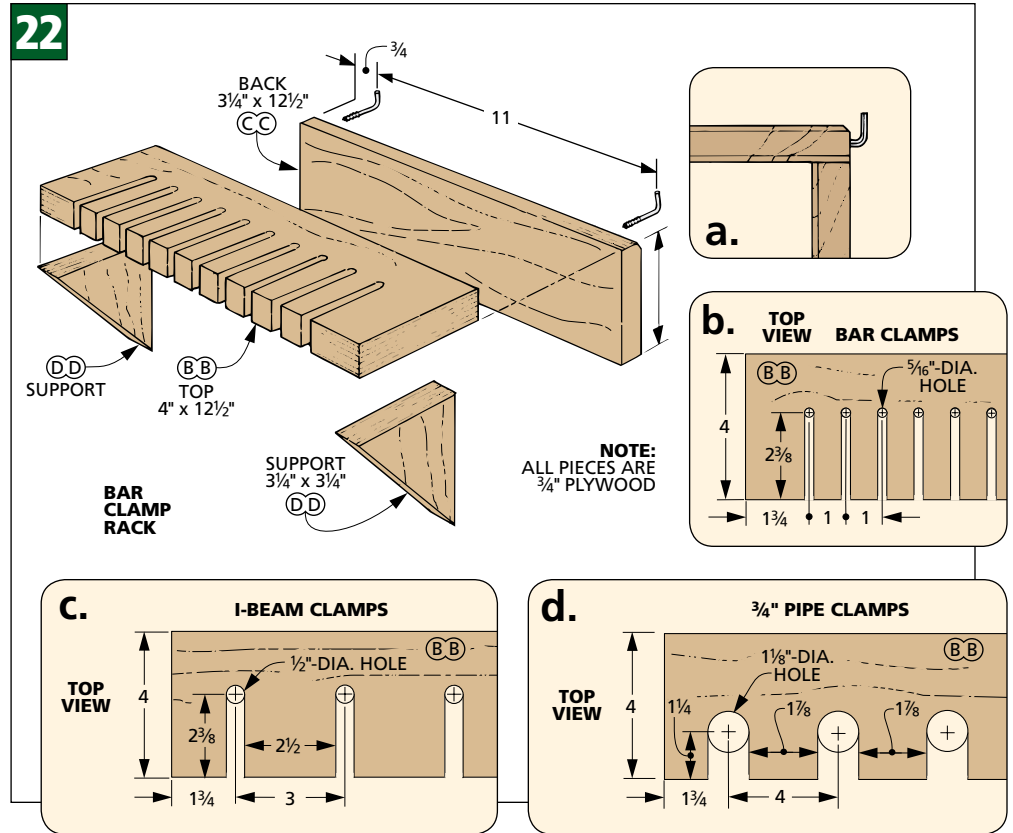

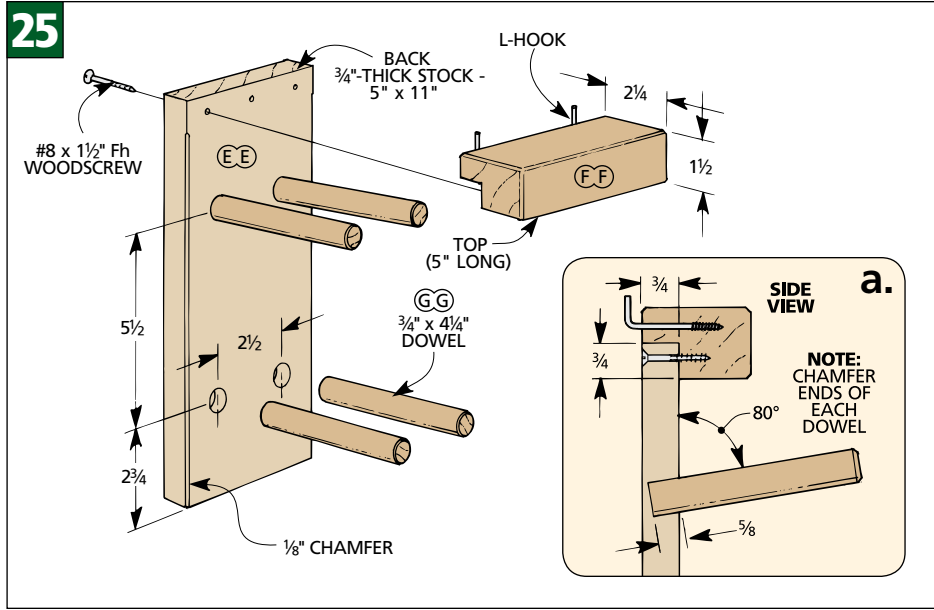

C-Clamp Rack

Storing C-clamps has always been a challenge, but as I mentioned earlier, you can easily build a rack to keep them organized on your pegboard system. The small holder you see here lets you slip C-clamps on or off

a pair of dowels without having to open or close the clamps. The rack consists of a base, a top, and two pairs of dowels to hold the clamps.

To prevent the clamps from sliding off the $4\frac{1}{4}$ "-long dowels, I

drilled each $\frac{3}{4}$ "-dia. hole in the back at an 80° angle (Figure 25a).

To provide a place to install the L-hooks, I made a top that was $2\frac{1}{4}$ " wide and $1\frac{1}{2}$ " thick. Then I rabbeted the back to fit over the base.

Saw & Square Holders

If you take a close look at the tool holders shown in the photos at right, you'll see they're like a combination of the shelf on page 5 and the chisel and screwdriver racks on page 6. They're designed to hold up to three pull saws or three squares.

For the pull saws, all that needs to be done is to cut an angled slot for each saw in the front of the shelf. Then just glue the shelf to a narrow back. Again, there is plenty of room on the shelf for the L-hooks to screw into.



The holder for the squares also has slots. But as you can see, these are short kerfs cut in the ends of the shelf

for the blade of the square. To keep the squares aligned, I cut shallow grooves centered on each slot.

